

Shepherd Lap Harp



Musicmaker's Kits

PO Box 2117
Stillwater MN 55082

(651) 439 9120 info@musikit.com

Parts List:

- a) 1 Walnut Neck/Pillar assembly
- b) 2 Walnut Sides
- c) 1 Walnut Bottom
- d) 1 Walnut Shoulder
- e) 1 Birch Soundboard
- f) 1 Walnut Center strip
- g) 1 Walnut/Cherry Back
- h) 1 Walnut Base
- i) 1 Walnut Overlay

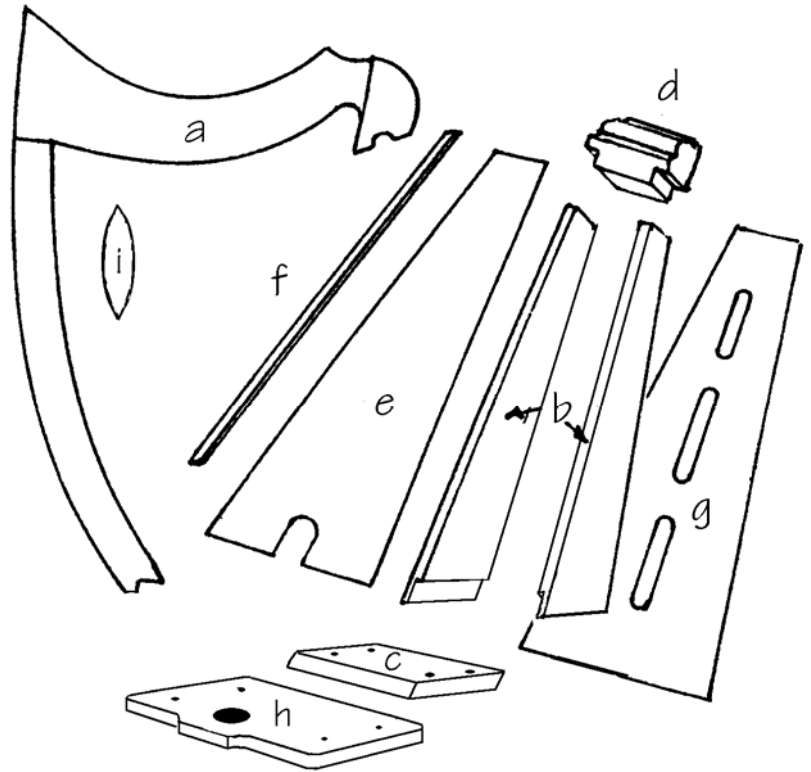

Hardware List:

- 22 Tuning Pins
- 22 Threaded Brass Guide Pins
- 22 Small Brass Eyelets
- 9 Wood screws, 1-5/8"
- 1/2 Oz. wire nails, 3/4" X #18
- 1 Drill Bit, 3/32" for soundboard
- 6 Ft Walnut Veneer tape
- 1 L-Handle Tuning Wrench
- 1 Set of 22 strings
- 1 Set of Assembly Instructions

A NOTE ABOUT GLUE

Find a good woodworking glue. We build our harps with modern woodworking adhesives, such as Elmer's Carpenter's Wood Glue or Titebond. DO NOT assemble this project with epoxy or superglue or hot melt glue. The yellow-colored Elmer's is best.

When gluing parts together, be sure to put enough glue on the joint to wet the entire surfaces to be joined. A good sign of proper gluing is that a little excess will squeeze out around the joint when clamping pressure is applied. Too little glue may cause the parts to separate later, whereas too much glue makes things messy. We always keep a damp rag handy for quick cleanup, as necessary. It is especially helpful to keep your fingers clean while gluing, because sticky fingerprints have the embarrassing tendency to appear on the finished product in places you never expected....

Most woodworking adhesives "set" sufficiently after 30 minutes of clamping to allow you to proceed. Check your dispenser for recommended drying times.

ASSEMBLY INSTRUCTIONS

Please check over the parts in your kit to make sure nothing is missing. Call us right away if you find a problem so we can correct it without causing a delay in your progress.

THE HARP FRAME

____ 1. You will use the two SIDES, the SHOULDER and the BOTTOM for assembling the main frame of the soundchamber. Note that there is a "front" and "back" to each of these pieces. Arrange the pieces without glue first to make sure everything fits well.

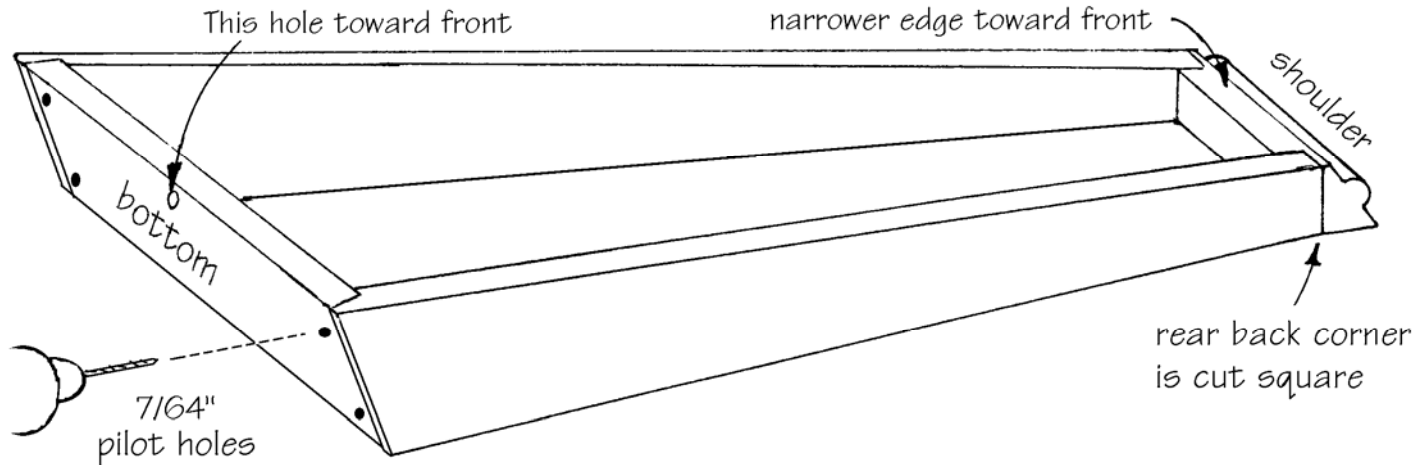

NOTE: There are five holes already drilled through the BOTTOM piece and they are countersunk on the outside, so when you put the BOTTOM on, the countersunk side should be facing outward. Carefully drill pilot holes through the BOTTOM into the SIDES, so the wood does not split when installing screws.

When satisfied with the fit, assemble the harp frame with glue, using screws to draw the BOTTOM up tightly, and clamps or tape to hold the SIDES firmly to the SHOULDER until dry. You can check to verify if the frame is square by measuring diagonally from each corner of the BOTTOM to each opposite corner of the SHOULDER. Equal measurements mean the frame is square.

THE BACK

____ 2. While the glue is drying on the frame, you may cut the access holes in the BACK panel. Use a saber saw, hand coping saw or a jig saw with a fine tooth blade in it to avoid chipping. Drill a pilot hole inside the outline so that you can get your saw blade in and then saw slowly, taking your time, keeping the blade just inside the penciled line. Then sand the holes right to the line and smooth out any irregularities.

HINT: A drum sanding attachment to your drill (1" diameter #100 grit sandpaper works well) is a great little tool for eliminating the rough spots and rounding things out.

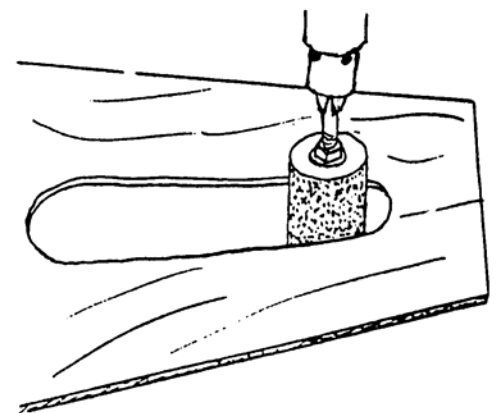

___3. Select which face of the BACK that you want to show outward on the harp. We have provided a plywood that has walnut on one face and cherry on the other. Both woods look nice together, so you may choose whichever face you like the best to show outward on the back of the instrument.

Put the frame on your work surface with the front edge down. Clean up any excess glue from the corners with a chisel or knife blade, or coarse sandpaper wrapped around a block of wood, so that the surfaces are smooth for gluing. Also, inspect the joints for unevenness, smoothing off any ridges or lips with your sanding block.

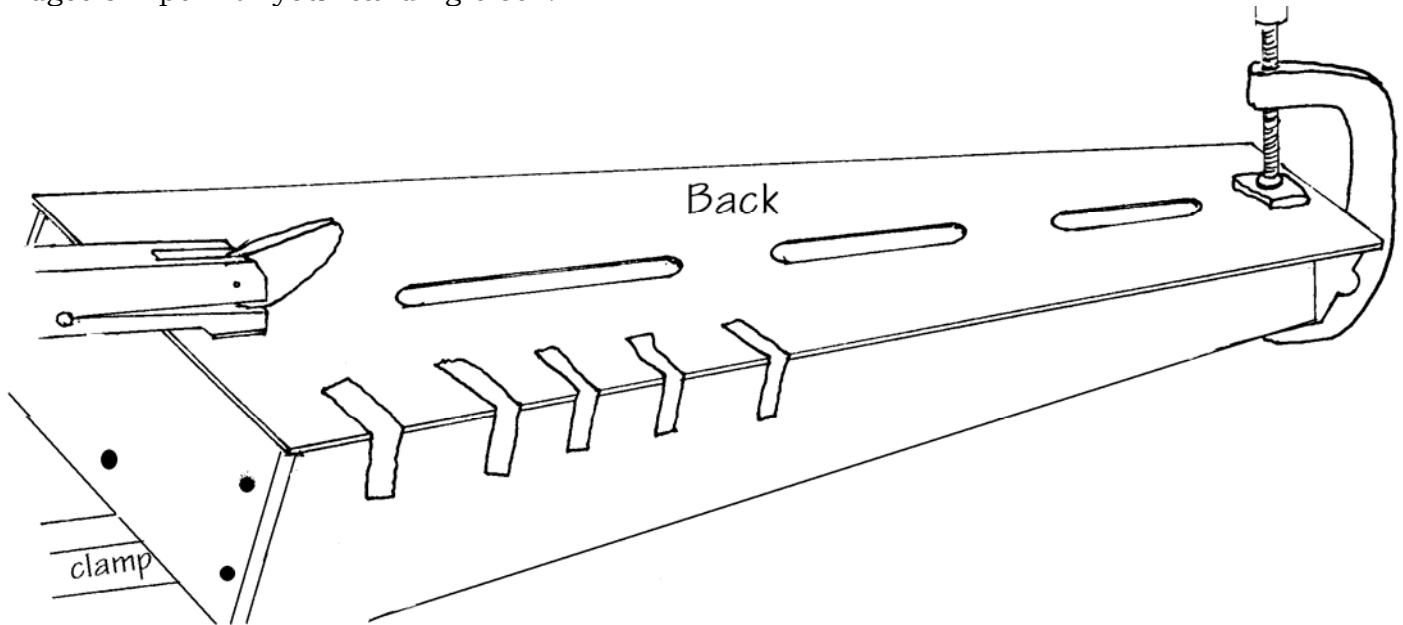

___4. Position the BACK on the frame with the good side up (whichever face you prefer). It will overlap the frame slightly, all the way around.

When satisfied with the fit, lift the BACK off the frame and squeeze a fairly heavy bead of glue along the edges of the frame. Put the BACK in place again and use clamps, weights, and/or many strips of masking tape to hold it firmly to the frame until the glue dries. Make sure the BACK remains positioned correctly under the pressure of the clamps.

Check all around the frame for any open cracks. If you need to add more clamps or weight to draw the parts together, do it now before the glue dries.

THE SOUNDBOARD

___5. The SOUNDBOARD needs some preparation before it can be attached to the frame. First, decide which face will be the outside and which will be the inside. There should be a notch drawn at the bottom of the board indicating our choice for the outside, but if you choose the other side that is perfectly OK. You may draw the outline of the notch on the other side.

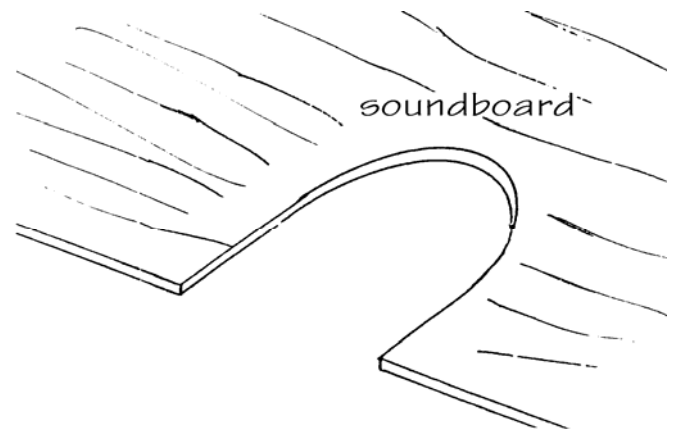

___6. Cut the notch at the wide end, as drawn on the wood. Sand the edges of the notch now, while they are easy to work on.

___7. The front of the SOUNDBOARD needs to be sanded to remove any glue or roughness. Sand with the grain, using a medium grade sandpaper (150 grit). An orbital sander also works well for this job. The sanding is more easily done now before the CENTER STRIP is put on it.

___8. Note that the hardwood CENTER STRIP has small punch-marks on one face, showing where the string holes will be drilled later. This is the front face of the strip. Sand the strip to round over the sharp edges on that front face, as shown, but do not remove the punch marks!

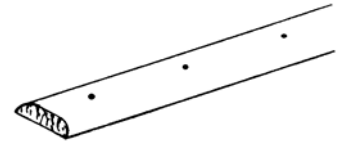

___9. Draw a center-line down the front of the SOUNDBOARD, from the top down to the notch. The hardwood CENTER STRIP will be glued on this line.

IMPORTANT: Please note which end of the CENTER STRIP goes toward the top of the harp. The string holes are spaced differently from top to bottom, so you must orient this strip correctly. The top end has a couple inches of blank space, without punch marks, and it may extend beyond the top of the SOUNDBOARD. You can chop off the excess length later..

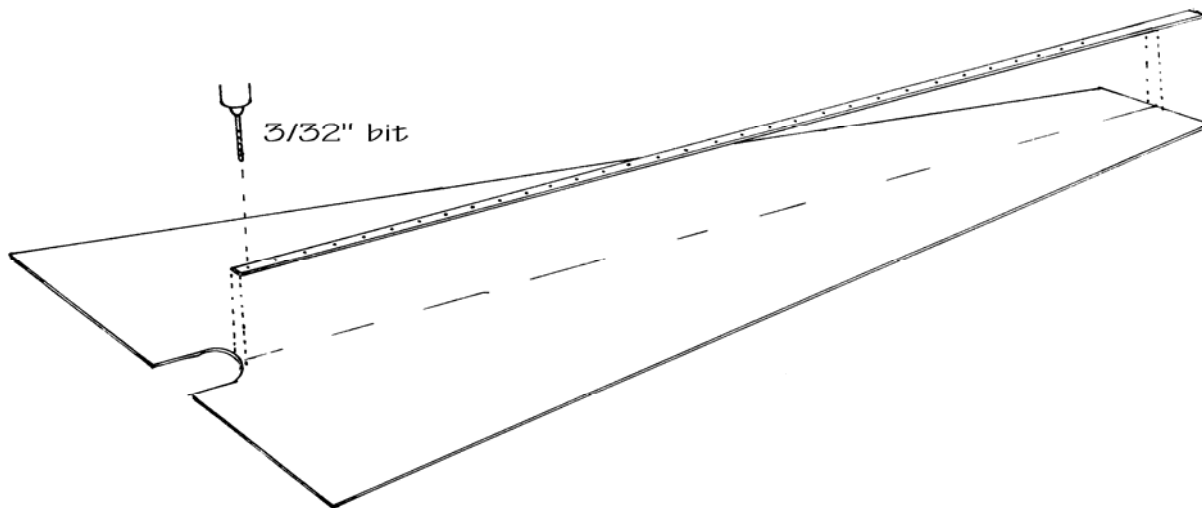

___10. Spread glue on the underside of the CENTER STRIP and put it in position on the SOUNDBOARD. Use masking tape at several locations to keep the STRIP straight and centered. Then apply clamps or weights to press it firmly to the SOUNDBOARD until the glue dries.

___11. When dry, use a 3/32" drill bit to bore 22 holes for the strings at the positions of the punch marks. The holes are to be all drilled all the way through the CENTER STRIP and the SOUNDBOARD, straight down (perpendicular to the wood), not at an angle.

**We suggest that you sign your name and the date
on the back of the soundboard
so that you will be able to see it
through the access holes in the BACK.**

___12. Test fit the SOUNDBOARD to the front of the harp frame. The string tension will try to peel the SOUNDBOARD off the frame of your harp, so it is very important to fasten it securely with both glue and nails all the way around the front of the harp. Draw a line around the perimeter of the SOUNDBOARD, 1/2" from the edge, to guide in the placing of nails.

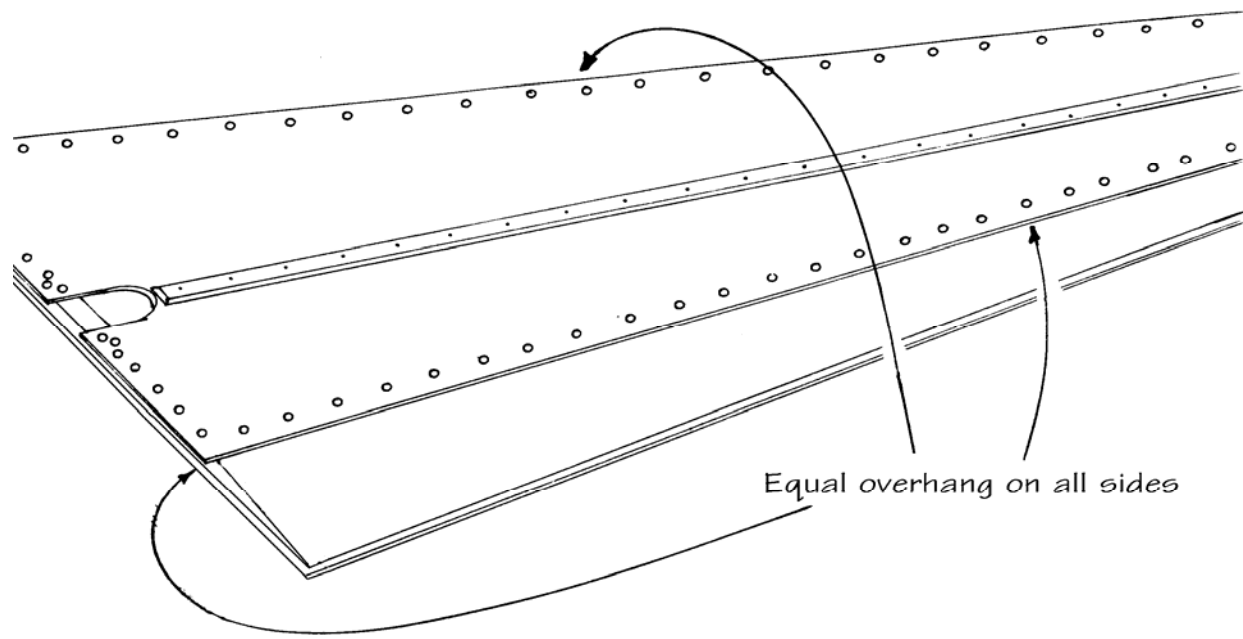

___13. Spread the glue on the frame (except where the notch is) and nail the **SOUNDBOARD** in place, making sure it is centered on the frame. We recommend spacing the nails about one inch apart, but It is a good idea to add a couple of extra nails near the notch, as shown, because there is a lot of tension and stress at this point.

Double-check around the entire frame to make sure the **SOUNDBOARD** is held tightly to the frame. Add more nails as necessary to draw the parts together firmly before the glue dries.

___14. Next, you'll want to clean up the soundchamber, trimming the **SOUNDBOARD** and **BACK** flush with the frame of the harp. An electric orbital sander makes quick work of this step, whereas sanding by hand will take some time. If you have only the hand-sanding option, begin with a very coarse sandpaper (60-80 grit) and wrap it around a block of wood. Use it like a rasp, with downward strokes until the edges of the **SOUNDBOARD** and **BACK** are flush with the soundchamber **SIDES**.

___15. Clean up all rough corners, glue smudges, and any other areas that need attention on the soundchamber. This is the part of the project that separates the experts from the amateurs. Do not rush through it! One sign of poor craftsmanship is glue spots around the joints or gluey fingerprints anywhere on the wood. Dried glue is hard to see now, but it will stand out like spinach in your teeth once the finish is applied.

___16. The decorative **VENEER TAPE** can be put on now to cover all the nails. Be sure to wipe off the dust from where these strips will go so they adhere well. You need not utilize the full width of the tape if you don't want to -- apply it just far enough to cover all the nails. The excess width can hang out over the edges and be trimmed off later.

CAUTION: Check the nail heads before installing the veneer tape. If any of them stick up above the surface of the wood, pound them in a little with a nail set.

Cut the **VENEER TAPE** to length with scissors, to frame the **SOUNDBOARD**. This wood tape is pre-glued. If there is a cellophane protective paper over the glue, peel that off first. Then lay the tape in place, covering the nails. Put the long strips down first on either side, and then cut shorter

strips to fit at the top and bottom. The notch interrupts the bottom strip.

___17. Use a household iron to warm up these strips (medium heat, no steam) by ironing them. This will make them adhere more permanently. Follow behind the iron with a scrap of wood to keep the pressure on the veneer as it cools down.

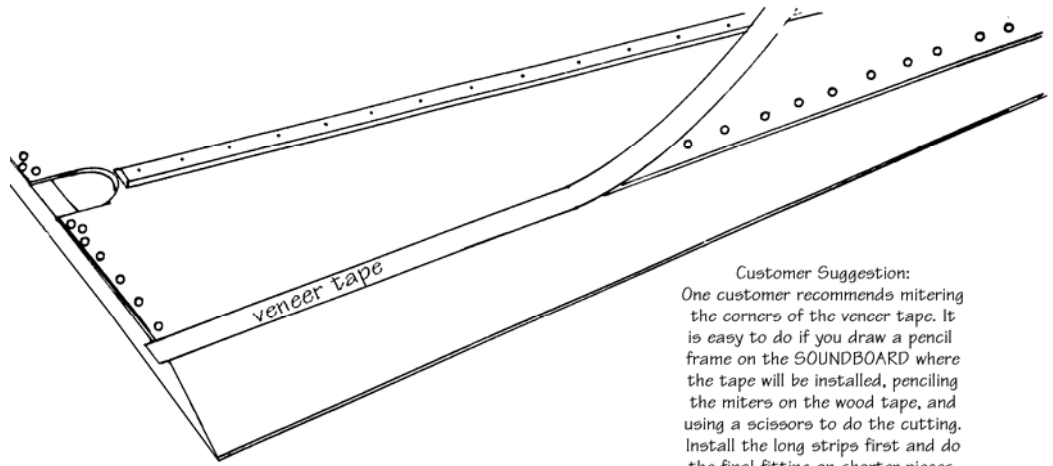

Customer Suggestion:
One customer recommends mitering the corners of the veneer tape. It is easy to do if you draw a pencil frame on the SOUNDBOARD where the tape will be installed, penciling the miters on the wood tape, and using a scissors to do the cutting. Install the long strips first and do the final fitting on shorter pieces.

PS. If the iron-on veneer should ever pull away from the surface, even after the instrument has been finished, there generally is no problem with ironing it back down again.

___18. Sand the sharp corners of the soundbox to round them over so they feel smooth. This is another step that will show off your woodworking prowess. A rounded corner looks and feels better than a sharp one.

___19. Install the LARGE BASE to the harp without glue. This is an optional piece that makes the harp more stable when standing on a table, but which you can remove if you want to make the harp lighter and more portable.

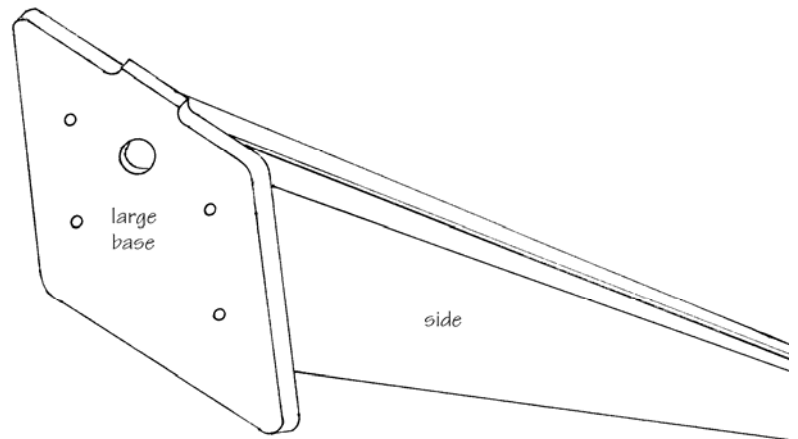

Note that most of the excess BASE should hang over the backside of the harp, to prevent the harp from tipping backwards. The large hole near the front should allow access to the screw which will hold the PILLAR to the BOTTOM of the harp.

Drill pilot holes first, and then use four screws to fasten the BASE to the bottom of the harp, as shown.

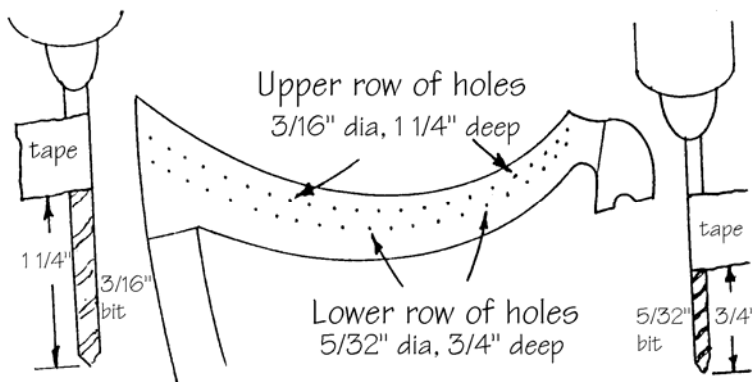

THE NECK/PILLAR

___20. If your harp NECK is not already pre-drilled, use a drill press, if possible, to bore the holes in the NECK in the positions shown by punch-marks on the wood. The upper row of holes are 3/16" diameter for TUNING PINS, and the lower row should be 5/32" for

the brass GUIDE PINS.

____21. Reinforce the NECK/PILLAR joint by gluing a DECORATIVE OVERLAY to just the “back side” of the joint, as shown. We don’t need one on the side where the pins are located.

Test-fit the NECK/PILLAR to soundchamber. If the NECK will not rest down on the SHOULDER, you may need to shave off some wood from the bottom of the PILLAR. This will lower the entire assembly.

If the PILLAR does not quite reach all the way to the BOTTOM of the frame, you may add thin strips of veneer tape to fill the gap inside the notch.

____22. Drill a 7/64" pilot hole up into the bottom of the PILLAR through the hole in the BOTTOM, making sure the PILLAR is centered in the notch. Insert a 1-5/8" screw into that hole to hold the PILLAR to the frame of the harp.

NOTE: Do not use any glue here. The NECK/PILLAR are not to be glued to the harp box - they will be held tightly in place by the string tension. In the future, you will be able to take your harp apart in case you ever want to repair or refinish it.

THREE CHEERS! Your harp is now completely assembled! After a final clean up and light sanding, all you have left is to protect the wood with the finish of your choice and then install the hardware and strings.

____23. This is a good time to decorate your harp before the final finish is applied. Decorative inlay, hand painting, decals, drawing or wood burning, etc. can add a special creative and personal touch.

Do your final sanding with about #220 grit sandpaper and always work with the grain so as not to scratch the wood.

THE FINISH

____24. Dust the harp with a clean rag before applying the finish

____25. Apply the finish of your choice. Here are a few guidelines on selecting a good protective coating:

STAIN -- STAINS are coloring agents and should only be used if you dislike the natural color of the wood. We usually do not apply stains to our projects, especially when they are made with naturally beautiful hardwoods such as cherry or walnut. These woods look very nice with just a clear finish. But, if you want to color the

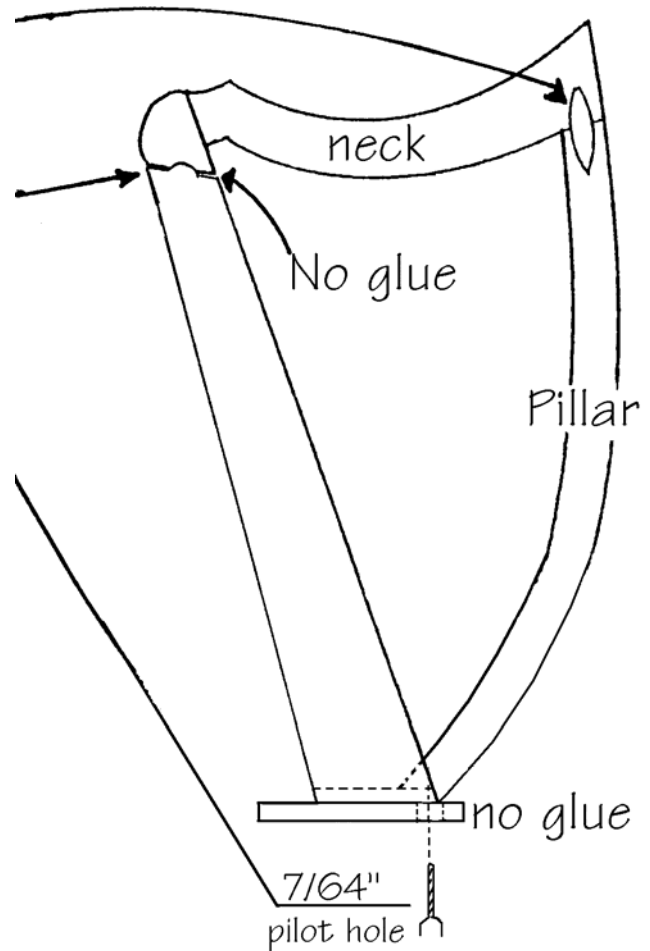

wood differently, your staining should be accomplished before applying a surface finish such as oil, varnish, or lacquer. We like ANILINE DYES for darkening the wood without obscuring the grain. Our 3-color powdered dyes (code *FINI-40*) can be mixed with denatured alcohol to the desired shade. The advantage of these dyes are quick drying time, deep colors, even penetration, and the opportunity to create a "sunburst" shading effect.

OIL -- An oil finish will give your wood a low luster appearance, bringing out the natural color of the grain, but it tends to soak into the wood and appear dry and "thirsty" after a while. The principal advantage of an oil finish is that it can be applied and wiped dry immediately, so you can proceed to installing hardware (and strings) right away. The disadvantages of oil are that it usually does not give much surface protection or sheen, although there are some brands that include waxes and/or varnishes to give more surface build-up and luster.

VARNISH -- Any regular varnish will work fine on this project, but we recommend our wipe-on polyurethane called MUSICMAKER'S INSTRUMENT FINISH. Our complete finishing kit (code *FINI-20*) includes detailed instructions, sandpaper sheets, tack cloth, foam applicator, and lint-free wiping cloth, along with a 1/2 pint can of semi-gloss polyurethane varnish. The advantages of finish are its simple application, durability, and deep, soft luster. It also works well for protecting Heat Transfer decorations.

LACQUER -- Many professional instrument makers still use lacquer for their finish. The most readily available lacquer is called Deft Clear Wood Finish. It is best to purchase a can of liquid to brush on as a sealer coat first, and then use an aerosol can of the same product to spray on the final coats. The advantage of this finish is its quick drying time, but the disadvantage is the strong odor of the toxic lacquer fumes. CAUTION: Lacquer finish will not work over Heat Transfer decorations -- it dissolves the toner.

INSTALLING HARDWARE

____26. Attaching the hardware is easier to do if the PILLAR/NECK piece is separated from the frame. Place a towel on your work table (under the NECK) to protect the wood while you pound.

You can install all the THREADED GUIDE PINS into the lower row of holes drilled in the NECK. We like to tap them partway in with a hammer and then screw them in with a **#1 size phillips screwdriver** until the threads are hidden in the wood. This will put each string about 1/2" above the surface of the wood, which is just about ideal.

Pound the TUNING PINS into the upper row of the holes into the neck. Be sure the threaded end goes into the wood. Pound them in until they stand about 1" above the wood.

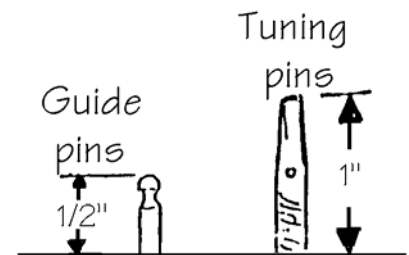

NOTE: If you pound a tuning pin in too deeply, you can raise it back up by turning it counter-clockwise with the tuning wrench.

____27. Find the little brass EYELETS and push them into the holes in the front of the SOUNDBOARD. These help prevent the strings from biting into the wood.

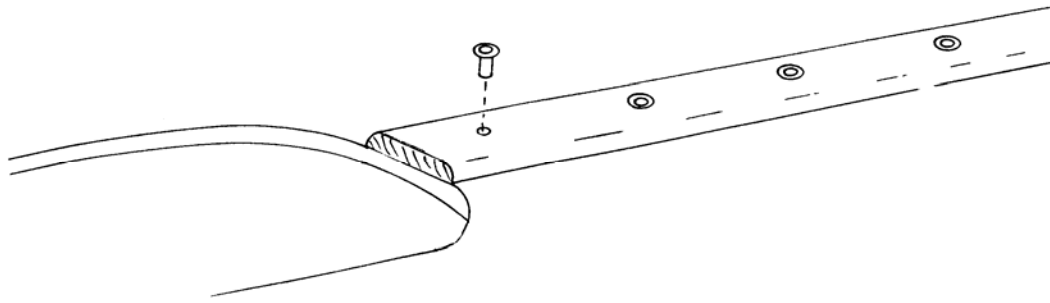

STRINGING & TUNING

____28. The strings are numbered with #1 being the smallest and #22 the largest. Some are colored to help as you play: "C" strings are red and "F" strings are blue.

NOTE: If the color on the strings should happen to fade, you can restore it with permanent magic marker.

Start at the bass (longest) end of the harp with #22. Push either end of the string through the lowest hole in the SOUNDBOARD from front to back. If it is a tight fit, you can trim the end at a taper with a sharp knife or scissors. Reach into the back of the harp and find the end. Slip a BEAD onto the string, and then tie a simple overhand knot at the end.

Put a drop of Superglue or Krazy glue on the knot to keep it from coming untied. Then pull the knot tightly against the inside of the SOUNDBOARD.

NOTE: PULL STRAIGHT THROUGH THE HOLE, NOT AT AN ANGLE, SO AS TO AVOID SCRATCHING THE NYLON AGAINST THE BRASS EYELET.

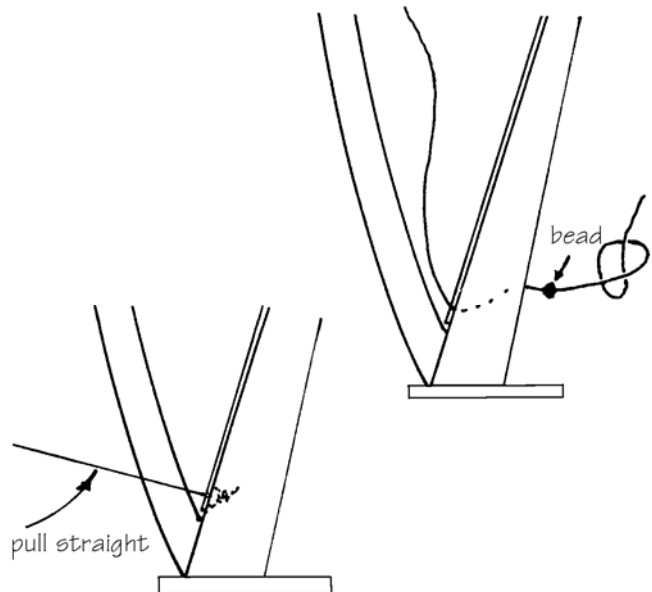

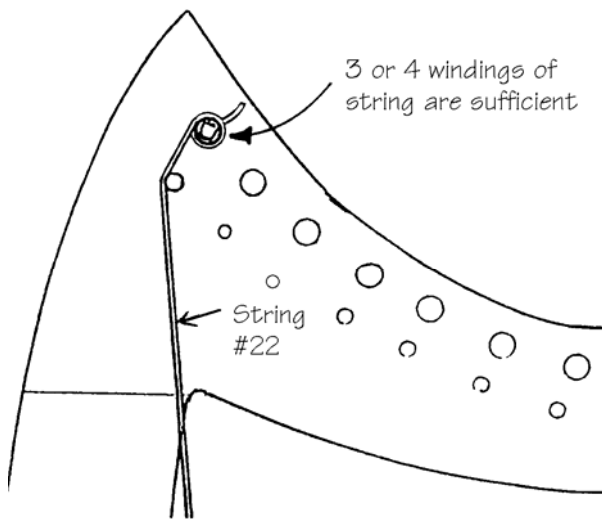

Thread the other end of the string through the last TUNING PIN at the point of the NECK. Pull it through the PIN until there is only a little slack in the string. Turn the PIN clockwise with the tuning wrench and guide the windings of the string downward toward the wood. As the string begins to tighten, place it in the groove of the GUIDE PIN.

HINT: Do not accumulate a lot of windings of string around the TUNING PINS, especially in the bass. They become bulky and cumbersome. If you find yourself with that problem, turn the TUNING PIN backwards to unwind the string, then pull some slack through the hole and tighten again.

Work your way up the harp, installing strings in this manner, keeping them in proper numerical order.

When you come to the mid-range strings (sizes .040 and .036), it is best to tie the bottom knot a little differently to give it more bulk. Start with the same overhand knot, but before tightening it, push the loose end part-way back into the knot, as shown, just to add one more thickness of string to the knot.

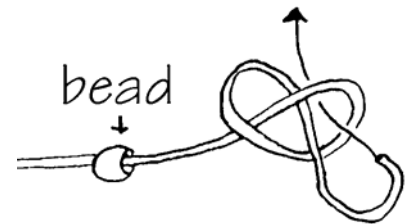

CAUTION: Nylon strings are somewhat fragile, especially in the upper octaves. Try to avoid scratching them as you install them. Most string breakage occurs at the tuning pin, when the string is pulled forcefully around the sharp corner of the small hole in the metal. You can minimize the problem by installing the strings carefully and by anchoring the windings before applying too much tension to the strings, so the nylon does not begin to slip back through the hole under tension and become scratched.

HERE IS HOW TO ANCHOR THE STRINGS TO THE TUNING PINS: Make one or two windings of string around the tuning pin, then cross the next winding over the others so the string is holding itself tightly around the PIN. Otherwise we often experience string slippage and breakage, especially in the upper half of the instrument.

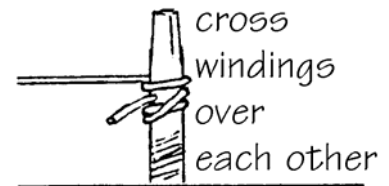

When all the strings are installed, tighten them to pitch and allow the instrument to adjust itself to the tension.

Many people are not certain if they are tuning their harp strings to the correct octave. Tuning the strings an octave too low will result in flabby harp strings that don't provide much volume. Tuning the strings too high will cause strings to break. To make sure you are tuning your harp strings to the correct octave, you can double-check the pitch on our website with our "online tuner". www.musikit.com

The strings should all be tuned to the natural C major scale (white keys on the piano). All the

red strings will be C notes and the blue ones F notes. Middle C is string number 19. Refer to our Harp Stringing and Tuning cassette for further help with these final steps.

NOTE: It will take several tunings before the harp will stay in tune. Be patient! It should get better each day.

CONGRATULATIONS! We hope you have enjoyed building this harp and that you enjoy many years of musical pleasure from playing it. We stock a good number of teaching materials and accessories for your instrument to help you get started. Just call us for more information or for placing an order.

SHARPING LEVERS

Sharping levers are used on folk harps to facilitate key changes. Installing a lever over a string allows you to raise the pitch of that string one-half step by engaging the cam handle against the string. Thus an F-string can be raised to F# by a simple flick of the lever. Similarly, a B-string may be tuned to Bb so that the lever will raise it to a B-natural and release it back to a B-flat, as needed

Most folk harp players set the key signature (sharps or flats) on the harp before starting each piece of music. For the key of G, you would engage the levers on all the F strings to produce the F# needed for that key (making sure all other notes on the harp are natural). If the following piece were then to be played in the key of F, you would then release the levers on all the F strings to produce F-natural, and also release all the B-string levers to produce Bb.

You may install a lever over every string on the harp, but if you think you may never use all of them, it would be more cost-effective to select which keys you think you are most likely to use, and then install only the levers necessary for those keys:

KEY OF G:	requires F#
KEY OF D:	requires F# and C#
KEY OF A:	requires F# and C# and G#
KEY OF F:	requires Bb
KEY OF Bb:	requires Bb and Eb
KEY OF Eb:	requires Bb and Eb and Ab

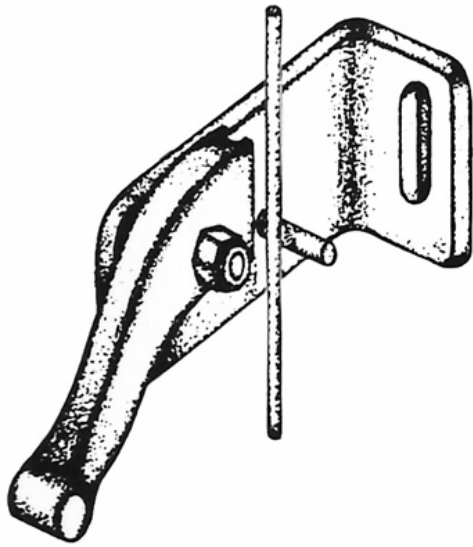

MUSICMAKER'S KITS, INC

P.O. BOX 2117
 STILLWATER, MN 55082
 (651) 439-9120
info@musikit.com

22- STRING LAP HARP

NYLON STRINGS

STRG-42	FULL SET OF 22 STRINGS	\$24.95
---------	------------------------	---------

STRING	NOTE	GAUGE	CODE	COLOR	STRING PRICE	VIBRATING LENGTH	SHARPING LEVER SIZE
1	G6	.025	NYLON-1	clear	\$.75	4-1/4"	00
2	F6	.025	NYLON-1	blue	.75	5-1/8	00
3	E6	.025	NYLON-1	clear	.75	6	00
4	D6	.025	NYLON-1	clear	.75	6-3/4	0
5	C6	.025	NYLON-1	red	.75	7-3/4	0
6	B5	.025	NYLON-1	clear	.75	8-5/8	0
7	A5	.025	NYLON-1	clear	.75	9-5/8	0
8	G5	.032	NYLON-3	clear	.75	10-1/2	2
9	F5	.032	NYLON-3	blue	.75	11-5/8	2
10	E5	.032	NYLON-3	clear	.75	12-5/8	2
11	D5	.036	NYLON-4	clear	1.00	13-3/4	4
12	C5	.036	NYLON-4	red	1.00	14-3/4	4
13	B4	.036	NYLON-4	clear	1.00	15-7/8	4
14	A4	.036	NYLON-4	clear	1.00	17-1/8	4
15	G4	.036	NYLON-4	clear	1.00	18-3/8	4

16	F4	.036	NYLON-4	blue	1.00	19-5/8	4
17	E4	.040	NYLON-5	clear	1.25	21-1/8	5
18	D4	.040	NYLON-5	clear	1.25	22-5/8	5
19	Middle C4	.040	NYLON-5	red	1.25	24-1/4	5
20	B3	.050	NYLON-7	clear	1.50	25-7/8	7
21	A3	.050	NYLON-7	clear	1.50	27-3/4	7
22	G3	.050	NYLON-7	clear	1.50	29-3/4	7

NOTE: 22 BEADS ADDED FOR ALL STRINGS

MUSICMAKER'S KITS, INC.
P.O. BOX 2117
STILLWATER, MN, 55082
(651) 439-9120